

Single-Axis Robot KC Series

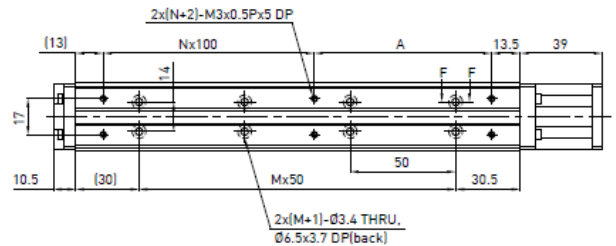

ข้อมูลจำเพาะ

KC30

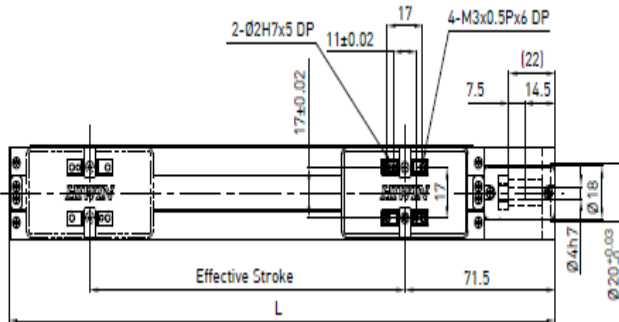

Effective Stroke (mm)	L	A	M	N	Weight (kg)	W/O Cover WT. (kg)
50	160	84	1	0	0.28	0.24
100	210	34	2	1	0.34	0.3
150	260	84	3	1	0.4	0.36

หมายเหตุ: ปลายแกนบอลสกรูขนาดเส้นผ่าศูนย์กลาง 3 (mm)

KC40

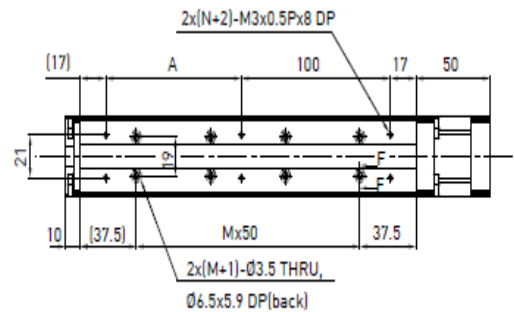
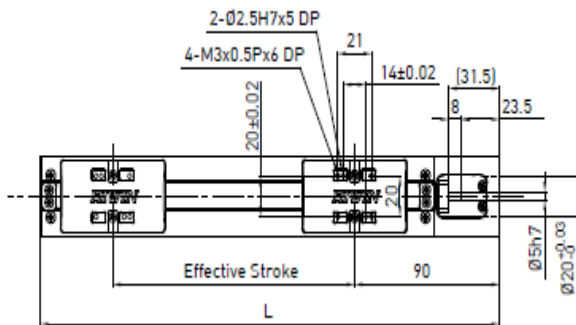

Effective Stroke (mm)	L	A	M	N	Weight (kg)	W/O Cover WT. (kg)
50	185	91	1	0	0.6	0.5
100	235	41	2	1	0.7	0.6
150	285	91	3	1	0.8	0.7
200	335	41	4	2	0.9	0.8

หมายเหตุ: ปลายแกนบอลสกรูขนาดเส้นผ่าศูนย์กลาง 4 (mm)

KC50

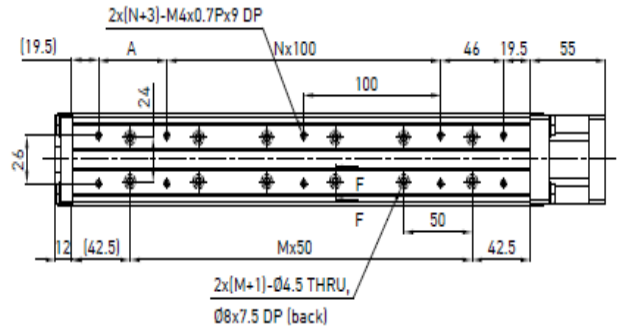
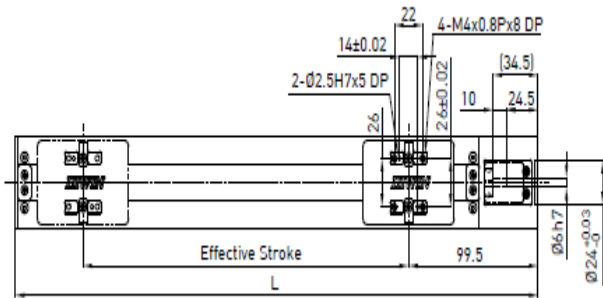

Effective Stroke (mm)	L	A	M	N	Weight (kg)	W/O Cover WT. (kg)
50	202	50	1	0	1.1	1
100	252	100	2	0	1.2	1.1
150	302	50	3	1	1.4	1.2
200	352	100	4	1	1.5	1.4
250	402	50	5	2	1.6	1.5
300	452	100	6	2	1.8	1.6

หมายเหตุ: ปลายแกนบอลสกรูขนาดเส้นผ่าศูนย์กลาง 5 (mm)

KC60

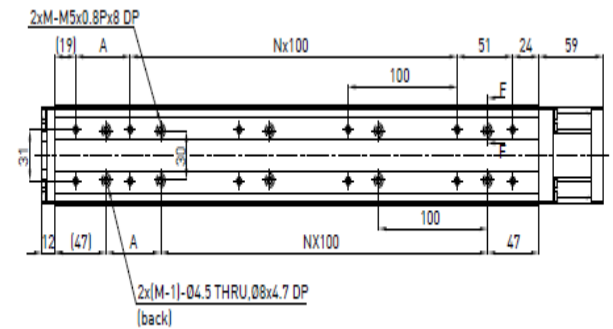
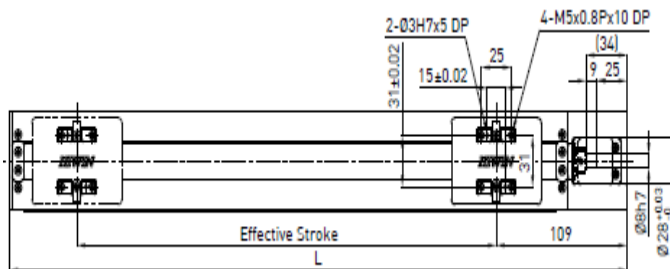

Effective Stroke (mm)	L	A	M	N	Weight (kg)	W/O Cover WT. (kg)
50	215	50	3	0	1.4	1.1
100	265	100	3	0	1.5	1.2
150	315	50	4	1	1.7	1.4
200	365	100	4	1	1.8	1.5
250	415	50	5	2	2	1.7
300	465	100	5	2	2.1	1.8
350	515	50	6	3	2.3	2
400	565	100	6	3	2.4	2.1
450	615	50	7	4	2.6	2.3
500	665	100	7	4	2.7	2.4
550	715	50	8	5	2.9	2.6
600	765	100	8	5	3	2.7

เข้าสู่ขั้วมอเตอร์และหน้าแปลนอะแดปเตอร์หลากหลายยี่ห้อสำหรับรุ่นKC

HIWIN Servo Motor

Model selection	Rated Output	Brakes	Flange Selection			
			KC30	KC40	KC50	KC60
M05□	50W	Without	F4	F2	F2	F2
K05□		With				
M10□	100W	Without	F4	F2	F2	F2
K10□		With				

◎ KC30

Motor Adaptor Flange F2

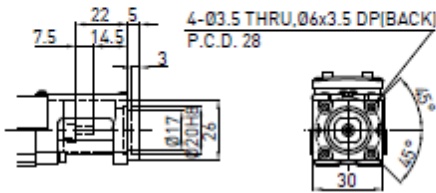

Motor Adaptor Flange F4

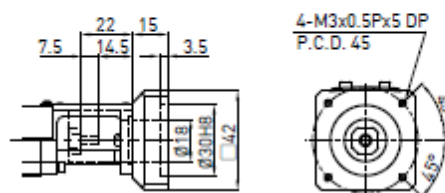

◎ KC40

Motor Adaptor Flange F1

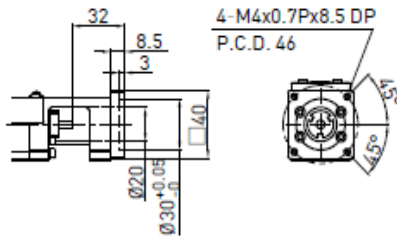

Motor Adaptor Flange F2

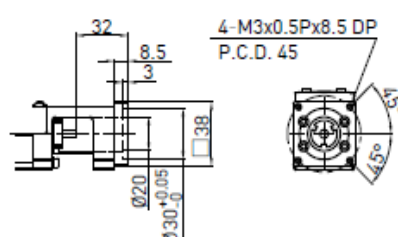

Mount Housing H0

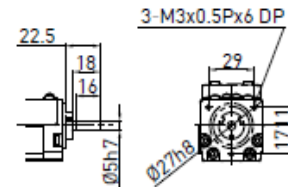

◎ KC50

Motor Adaptor Flange F1

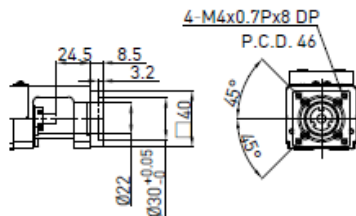

Motor Adaptor Flange F2

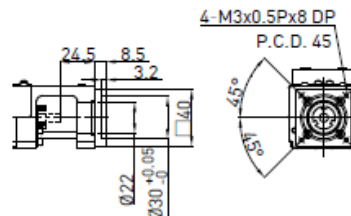

Mount Housing H0

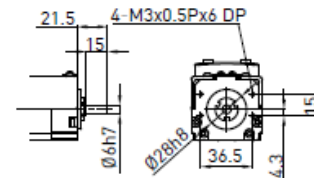

◎ KC60

Motor Adaptor Flange F1

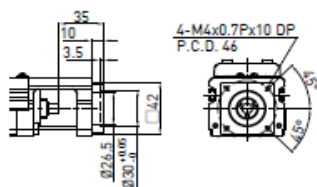

Motor Adaptor Flange F2

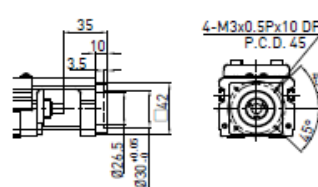

Mount Housing H0

